

Configuration for version 1.x 690+.

Important! Configurations display configurable connections and parameters only.	DWN		SIZE	DWG. NO.
	CHK		D:\CELITE\New_5.690	
	APP		ISSUE	1
			SCALE	SHEET 1 OF 6

Menus

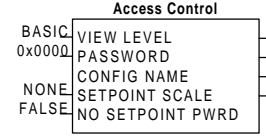
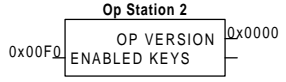
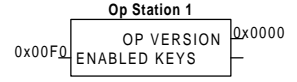
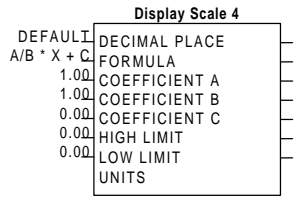
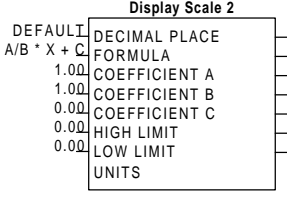
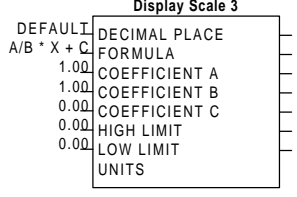
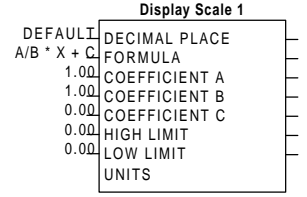
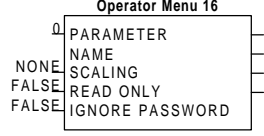
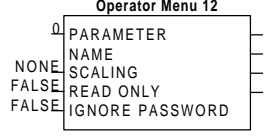
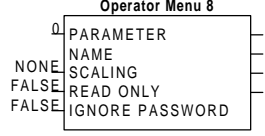
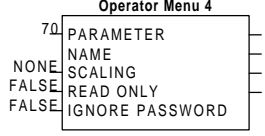
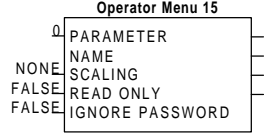
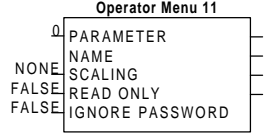
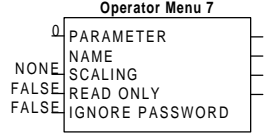
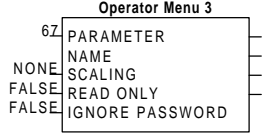
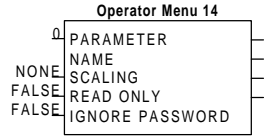
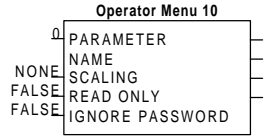
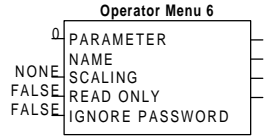
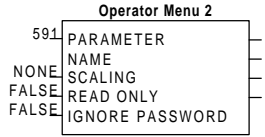
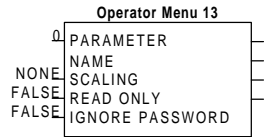
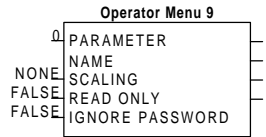
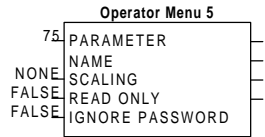
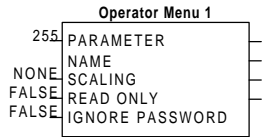

Configuration for version 1.x 690+.

Important! Configurations display configurable connections and parameters only.	DWN			SIZE A	DWG. NO.
	CHK		D:\ICELITE\New_5.690	ISSUE	1
	APP			SCALE	SHEET 2 OF 6

Motor Control

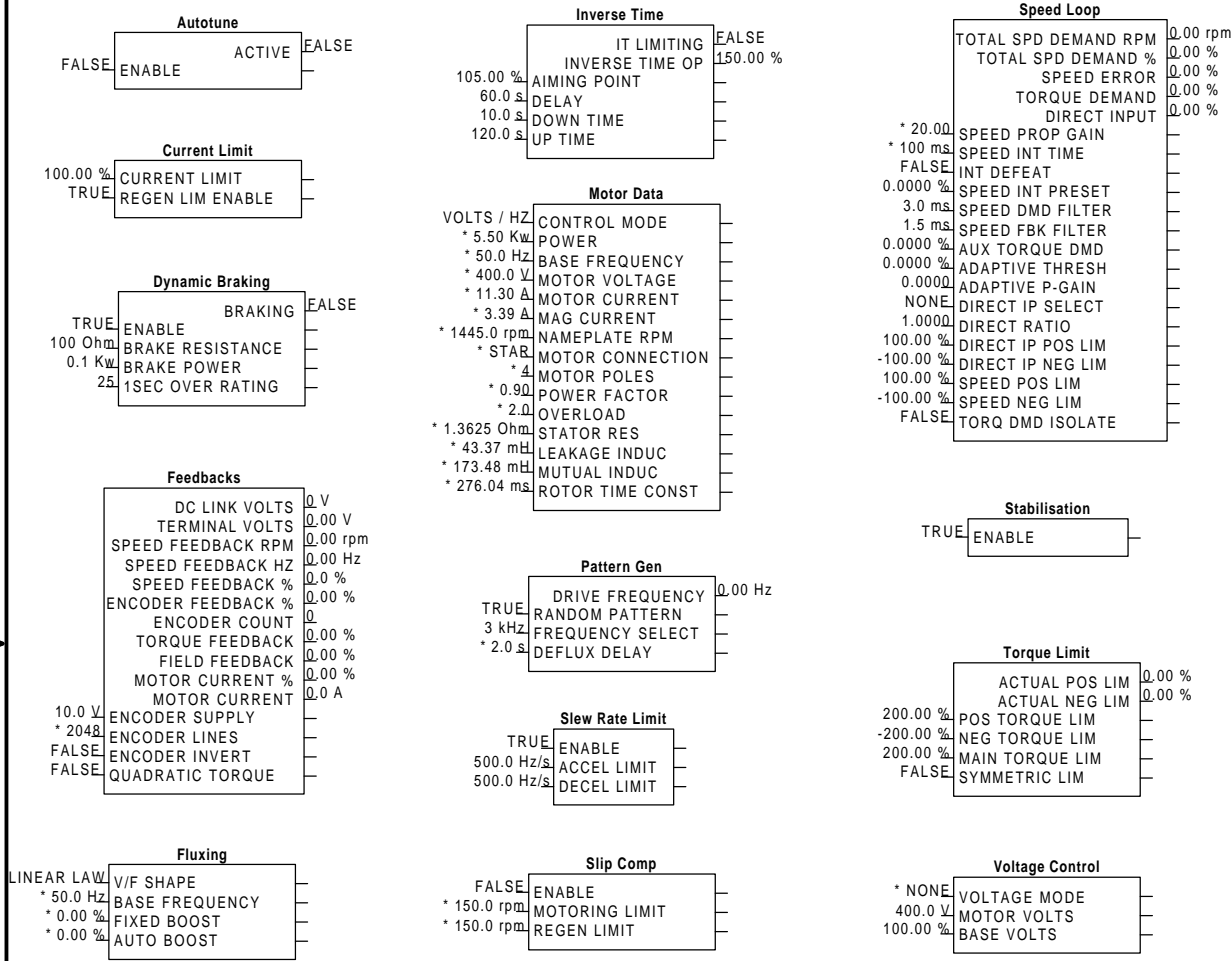

Sequencing and Reference

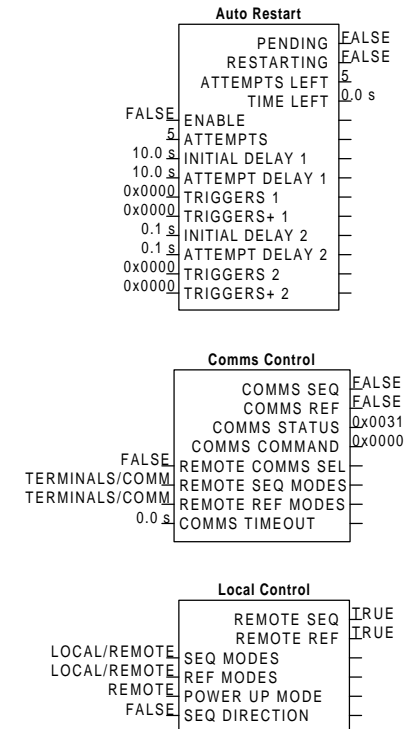

Communications

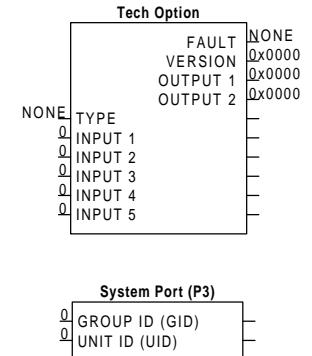

Configuration for version 1.x 690+.

Important! Configurations display configurable connections and parameters only.	DWN			SIZE	DWG. NO.
	CHK		D:\CELITE\New_5.690	ISSUE	1
	APP			SCALE	SHEET 3 OF 6

Setpoint Functions

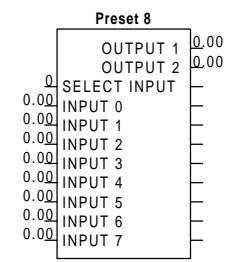
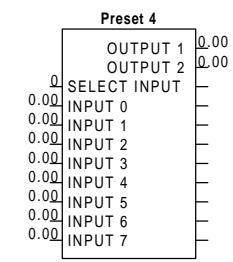
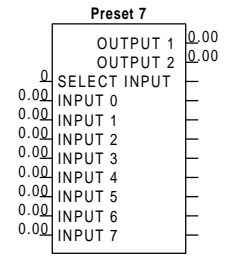
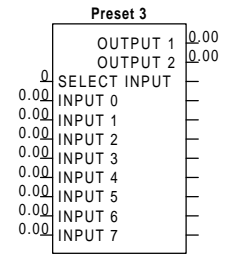
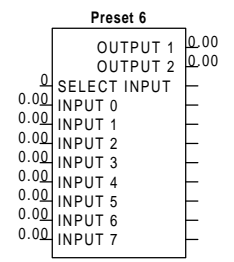
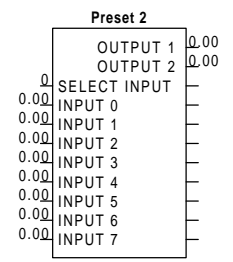
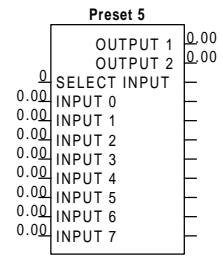
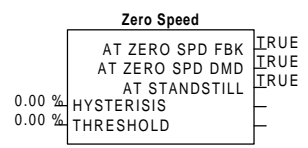
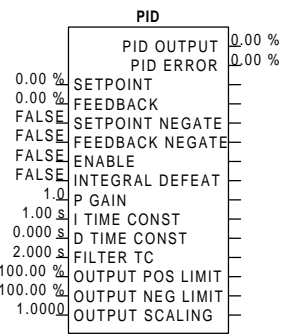
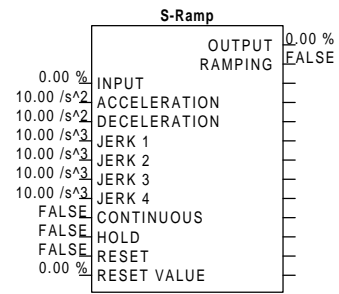
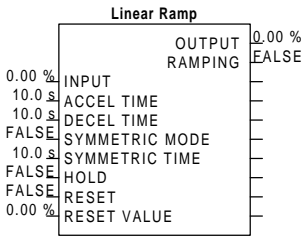
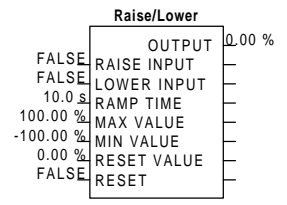
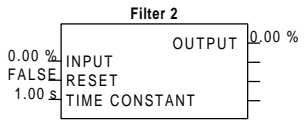
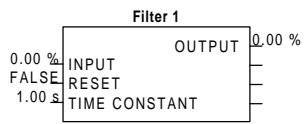

Trips

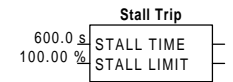
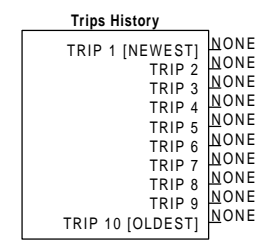

Hoist/Lift

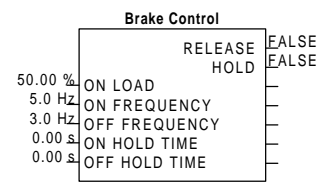

Configuration for version 1.x 690+.

Important! Configurations display configurable connections and parameters only.	DWN		SIZE A	DWG. NO.
	CHK		D:\ICELITE\New_5.690	
	APP		ISSUE 1	SCALE
			SHEET	4 OF 6

Winder

Compensation	
COMPENSATIONS	0.00 %
INERTIA COMP	0.00 %
SCALED RATE	0.00 %
LINE SPEED RATE	0.00 %
10.00 % DIAMETER	
10.00 % MINIMUM DIAMETER	
0.00 % VARIABLE INERTIA	
0.00 % FIXED INERTIA	
0.00 % WIDTH	
FALSE UNWIND	
0.00 % LINE SPD DEMAND	
0.00 % RATE CAL	
FALSE REVERSE	
0.00 % DYNAMIC COMP	
0.00 % STATIC COMP	
0.00 % MOD WINDER SPEED	

Diameter Calc	
CURRENT CORE	10.00 %
DIAMETER	10.00 %
MOD LINE SPEED	0.00 %
MOD WINDER SPEED	0.00 %
FALSE DIAMETER HOLD	
FALSE PRESET ENABLE	
FALSE SELECT CORE 2	
FALSE SEL EXT DIAMETER	
FALSE TENSION ENABLE	
10.00 % CORE 1	
10.00 % CORE 2	
5.00 % DIAMETER TC	
0.00 % EXT DIAMETER	
0.00 % LINE SPEED	
10.00 % MINIMUM DIAMETER	
5.00 % MINIMUM SPEED	
0.00 % WINDER SPEED	

Speed Calc	
SPEED DEMAND	0.00 %
UP TO SPD (UTS)	TRUE
FALSE UNWIND	
FALSE OVER-WIND	
FALSE OVER SPD ENABLE	
5.00 % UTS THRESHOLD	
0.00 % LINE SPEED	
0.00 % MOD WINDER SPEED	
10.00 % DIAMETER	
10.00 % MINIMUM DIAMETER	
0.00 % OVER SPEED	
0.00 % SPEED TRIM	

Taper Calc	
TAPERED DEMAND	0.00 %
TENSION DEMAND	0.00 %
FALSE HYPERBOLIC TAPER	
FALSE STALL ENABLE	
FALSE BOOST ENABLE	
FALSE FIXED BOOST	
FALSE FIXED STALL TENSION	
0.00 % CURRENT CORE	
10.00 % DIAMETER	
0.00 % BOOST	
1.000 % TENSION RAMP	
0.00 % STALL TENSION	
0.00 % TAPER SPT	
0.00 % TENSION SPT	

Torque Calc	
POS TORQUE LIMIT	±200.00 %
NEG TORQUE LIMIT	±200.00 %
FALSE OVER-WIND	
FALSE TENSION ENABLE	
0.00 % TENSION DEMAND	
200.00 % TORQUE LIMIT	

Configuration for version 1.x 690+.

Important! Configurations display configurable connections and parameters only.	DWN			SIZE A	DWG. NO.
	CHK		D:\CELITE\New_5.690	ISSUE	1
	APP			SCALE	SHEET 5 OF 6

Miscellaneous

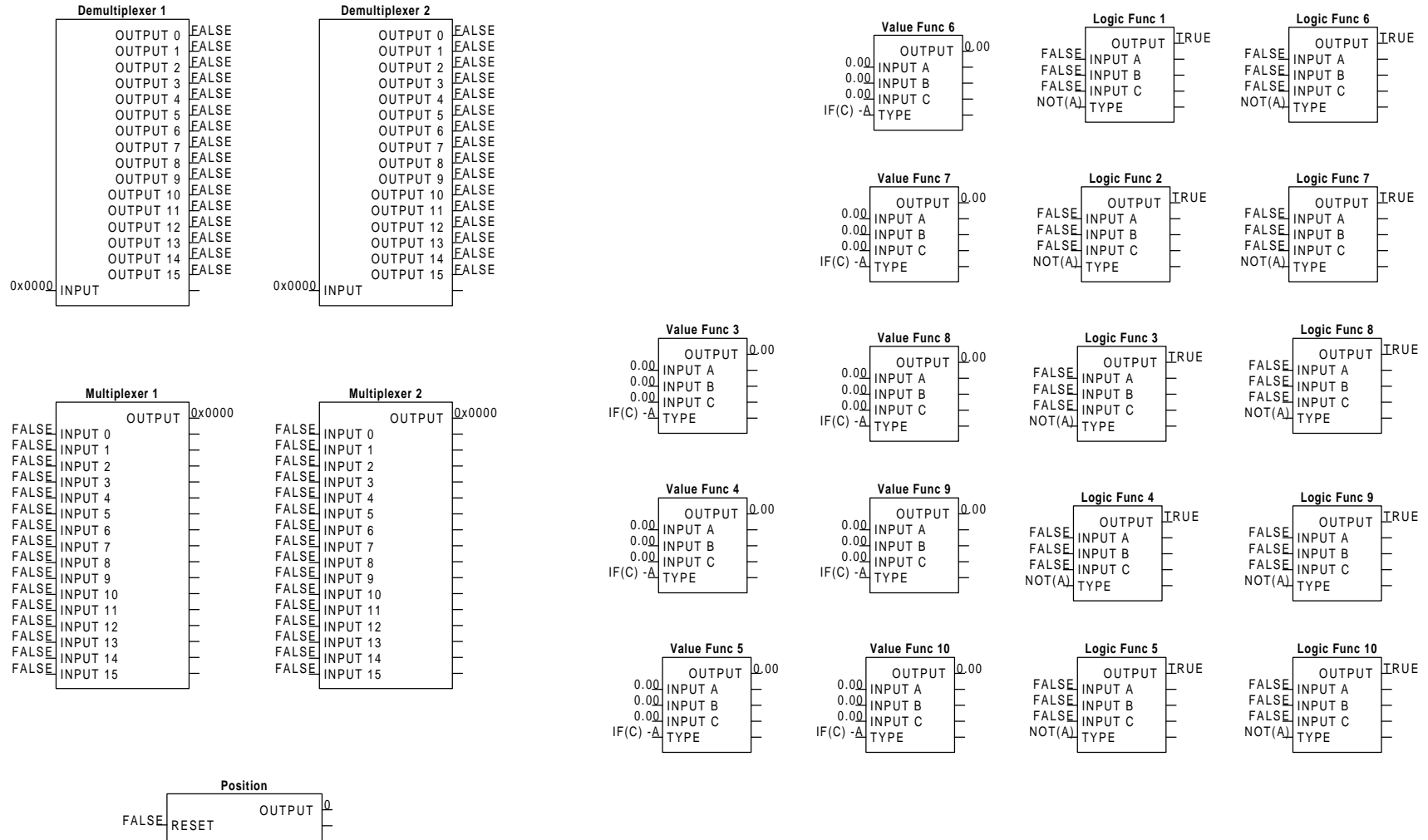

Configuration for version 1.x 690+.

Important! Configurations display configurable connections and parameters only.	DWN		SIZE A	DWG. NO.
	CHK		D:\CELITE\New_5.690	
	APP		ISSUE 1	SCALE
			SHEET	6 OF 6