

- 6-pen multipoint
- Roll or Z-fold chart
- 3-Colour digital display
- User configurable, Universal, Isolated inputs
- Local or PC configuration
- Annotation
- Chart illumination
- 236 mm overall depth behind panel
- Front access to pen zero/span adjust
- Up to 12 relay outputs
- Ready for immediate use.

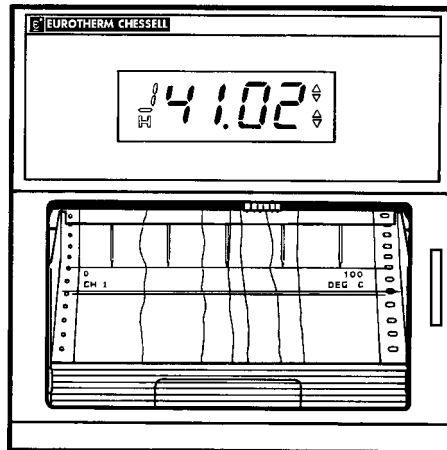

The 4102M is a low cost multipoint recorder, capable of plotting up to six input signals. Enclosed in a sheet steel case designed to meet the requirements of an industrial environment, the recorder is ideal for production or test purposes.

Display

The 4102M has a high resolution, 3-colour vacuum fluorescent display with 15 mm high blue digits for process value and a single 8mm green character for channel number. The display shows the process value for each of the input channels in turn, with indication of alarm status.

Small rear panel depth

The 4102M has a total depth behind panel of 236mm allowing it to fit easily into the standard range of 250mm deep panels.

Input technology

Use of the very latest in Application Specific Integrated Circuit (ASIC) and Surface Mount technologies, gives the 4102 input circuitry high accuracy and stability. Inputs are fully universal accepting any mix of thermocouple, resistance thermometer, potentiometer, mV or mA inputs.

Configuration

Configuration can be carried out from the recorder keypad, or using a PC based configuration package.

Annotation

The 4102M has annotation as standard, providing printing on the chart of scale end-points, units, time and chart speed, thus avoiding the necessity for expensive, specially printed charts. Power-up, and on/off-line messages are also automatically printed, and alarm on/off or event messages can be printed if required.

Chart Illumination

This option provides a fluorescent tube above the chart, making the traces significantly more visible, even in well lighted areas.

Operator interface

This consists of five membrane push-button switches, located adjacent to the display, allowing configuration of all the recorder functions. One password and three access levels are configurable to protect sensitive areas of the configuration.

Relay Outputs

Two alarm thresholds can be set up for each channel. With the relay output option fitted, these alarms are each assigned a relay which becomes de-energised when the current value lies above the high threshold or below the low threshold.

Three types of relay board are available:

3 x changeover, 4 x common/normally closed and 4 x common/normally open.

TECHNICAL SPECIFICATION (Input board)

General

Input types	DC Volts, dc millivolts, DC milliamps, Thermocouple, 2 / 3-wire RTD (Channel 1 can be RTD only if no other channels are thermocouple)
Input type mix	User configurable
Maximum number of inputs	6
Input ranges	- 30 to + 150 mV; - 0.2 to + 1 Volt; - 2 to + 10 Volts
Termination	Edge connector / terminal block
Noise rejection (48 to 62 Hz)	Common mode: >140dB (channel to channel and channel to ground). Series mode: >60dB.
Maximum common mode voltage	250 Volts continuous
Maximum series mode voltage	180 mV at lowest range; 12 Volts peak at highest range.
Isolation (dc to 65 Hz; BS EN61010)	Installation cat.II; Pollution degree 2 Channel to channel: 300V RMS or dc (double insulation) Channel to common electronics: 300V RMS or dc (double insulation) Channel to ground: 300V RMS or dc (basic insulation)
Dielectric strength (BS EN61010)	(One minute type tests) Channel to channel: 2300 Vac Channel to ground: 1350 Vac
Insulation resistance	>10 M Ω at 500 V dc
Input impedance	150 mV and 1 V ranges: >10 M Ω ; 10 V range: 68.8 k Ω
Over voltage protection	50 Volts peak (150V with attenuator)
Open circuit detection	\pm 57 nA max. Recognition time: 500 msec
Minimum break resistance	10 M Ω

DC Input ranges

Shunt/attenuator	Externally mounted resistor modules
Additional error due to shunt	0.1% of input
Additional error due to attenuator	0.2% of input
Performance	See table 1

Low Range	High Range	Resolution	Maximum error (Instrument at 20°C)	Worst case temperature performance
-30 mV	150mV	5.5 μ V	0.084% input + 0.053% range	80ppm of input per deg C
-0.2 Volt	1 Volt	37 μ V	0.084% input + 0.037% range	80ppm of input per deg C
-2 Volts	10 Volts	370 μ V	0.275% input + 0.040% range	272ppm of input per deg C

Table 1 DC performance

INSTALLATION CATEGORY II

The rated impulse voltage for equipment on nominal 230V mains is 2500V.

POLLUTION DEGREE 2

Normally, only non-conductive pollution occurs. Occasionally, however, a temporary conductivity caused by condensation shall be expected.

Input board specification (Cont.)

Thermocouple data

Temperature scale	ITS 90
Linearisation accuracy	0.05% of user selected span
Bias current	0.05 nA
Cold junction types	Off, internal, external
CJ error	1°C max; instrument at 25°C
CJ rejection ratio	50:1 minimum
Upscale / downscale drive	High, low or none
Types and ranges	See table 2

T/C Type	Overall range (°C)	Standard	Max linearisation error
B	0 to + 1820	IEC 584.1	0 to 400°C: 1.7°C 400 to 1820°C: 0.03°C
C	0 to + 2300	Hoskins	0.12°C
D	0 to + 2495	Hoskins	0.08°C
E	- 270 to + 1000	IEC 584.1	0.03°C
G2	0 to + 2315	Hoskins	0.07°C
J	- 210 to + 1200	IEC 584.1	0.02°C
K	- 270 to + 1372	IEC 584.1	0.04°C
L	- 200 to + 900	DIN43700:1985 (To IPTS68)	0.20°C
N	- 270 to + 1300	IEC 584.1	0.04°C
R	- 50 to + 1768	IEC 584.1	0.04°C
S	- 50 to + 1768	IEC 584.1	0.04°C
T	- 270 to + 400	IEC 584.1	0.02°C
U	- 200 to + 600	DIN 43710:1985	0.08°C
Ni/NiMo	0 to + 1406	Ipsen	0.14°C
Platinel	0 to + 1370	Engelhard	0.02°C

Table 2 Thermocouple types and ranges

Resistance inputs

Ranges (including lead resistance)	0 to 600 Ω , 0 to 6k Ω
Linearisation accuracy	0.05% of user entered span
Influence of lead resistance	Error = negligible; Mismatch = 1 Ω / Ω
Temperature scale	ITS90
Resolution and performance	See table 3
RTD types and ranges	See table 4

Low Range	High Range	Resolution	Maximum error (Instrument at 20°C)	Worst case temperature performance
0 Ω	600 Ω	22m Ω	0.045% input + 0.065% range	35ppm of input per deg C
0 Ω	6000 Ω	148m Ω	0.049% input + 0.035% range	35ppm of input per deg C

Table 3 Resolution and performance for resistance inputs

RTD Type	Overall range (°C)	Standard	Max linearisation error
JPT100	-220 to + 630	JIS C1604:1989	0.01 °C
Ni100	- 60 to + 250	DIN43760:1987	0.01 °C
Ni120	-50 to + 170	DIN43760:1987	0.01 °C
Pt100	-200 to + 850	IEC 751	0.01 °C
Pt100A	-200 to + 600	Eurotherm Recorders SA	0.09 °C
Pt1000	-200 to + 850	IEC 751	0.01 °C

Table 4 RTD types and ranges

TECHNICAL SPECIFICATION (Recorder)

Board types

Standard	Universal input / control board
Options	3- Change-over relay output board 4 Normally open relay o/p board 4 Normally closed relay o/p board Transmitter power supply Event input board

Environmental Performance

Temperature limits	Operation: 0 to 50°C. Storage: -20 to + 70°C
Humidity limits (non-condensing)	Operation: 5% to 80% RH Storage: 5% to 90% RH
Protection	Door and Bezel: IP54. Sleeve: IP20 Transmitter PSU rear cover: IP10
Shock	BS EN61010
Vibration	2g peak at 10 Hz to 150Hz
Altitude (max.)	<2000 metres

Power requirements

Line voltage	Standard: 90 to 264V at 45 to 65 Hz
Enhanced interrupt protection:	90 to 132V at 45 to 65 Hz
Low voltage option:	20 to 53V dc or 14 to 37V ac (45 to 400 Hz)
Power (Max)	< 100 VA
Fuse type	Not user accessible
Interrupt protection	Standard: 40 ms at 75% max. instrument load Enhanced: 120ms at 75% max. instrument load

Electromagnetic compatibility (EMC)

Emissions	BS EN50081-2
Immunity	BS EN50082-2
Electrical safety	To EN61010: Installation category II; Pollution degree 2

Physical

Panel mounting	DIN43700
Bezel size	144 x 144 mm.
Panel cutout dimensions	138 x 138 (both - 0 + 1 mm)
Depth behind bezel rear face	220 mm (No terminal cover); 236 mm (standard terminal cover) 275 mm (long terminal cover closed) 390mm (long terminal cover open)
Weight	< 3.5kg
Panel mounting	Vertical \pm 30°

Printing system

Pen type	Six-nib cartridge
Pen resolution	0.2 mm
Trace colours	See table 5
Pen life	1.5 x10 ⁶ dots per colour
Update rate	2 Hz
Print rate (maximum)	1 pass every 5 seconds
Characters per line	42

Channel	Colour	Channel	Colour
1	violet	4	green
2	red	5	blue
3	black	6	brown

Table 5 Trace colours

Recorder Specification (Cont.)

Paper transport

Type	Stepper motor driving sprocket tube
Chart speeds	Off, 5, 10, 20, 30, 60, 120 mm/hr
Chart type	Standard: 16 - metre z-fold Option: 32 - metre roll.
Transport accuracy	0.5 cm in 16 metres (approx. 0.03%)

Vacuum fluorescent display

Process value	Four, blue, 15mm high characters with minus sign as required
Channel number	Single, green 8 mm high character
Alarm indication	pair of red arrows for high and low alarms
Channel hold indication	Red 'H' below channel number when channel hold in operation
Keypad	5-key keypad for operator/configuration access

TECHNICAL SPECIFICATION (Options)

All isolation figures are Installation category II and Pollution degree 2

Relay outputs

Maximum switching power*	500VA or 60W
Maximum breaking current*	2 Amps within above power ratings
Maximum contact voltage*	250V within above power ratings
Isolation (dc to 65Hz; BS EN61010)	300V RMS or dc contact-contact (double insulation) and contact to ground (basic insulation).
Estimated life*	30,000,000 operations

* With resistive loads. With inductive loads, derate according to the graph, in which:

contact life = resistive life x F1 or F2 where F1 = measured on representative examples and F2 = typical values according to experience.

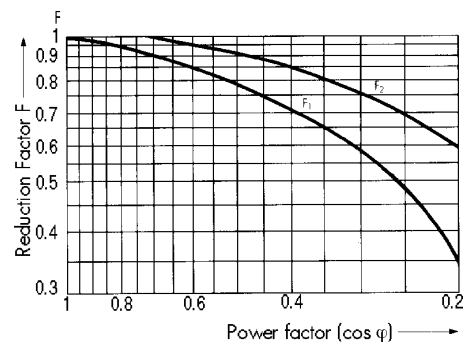

Event inputs

Isolation (dc to 65Hz; BS EN61010)	
Event input to ground:	100V RMS or dc (double insulation)
Event input to Event input:	0V

Transmitter Power Supply

Output voltage	3 or 6 x 25Vdc (nom) outputs
Isolation (dc to 65Hz; BS EN61010)	
Channel to channel:	100V RMS or dc (double insulation)
Channel to ground:	100V RMS or dc (basic insulation)
Cover rating	IP10

Mechanical installation

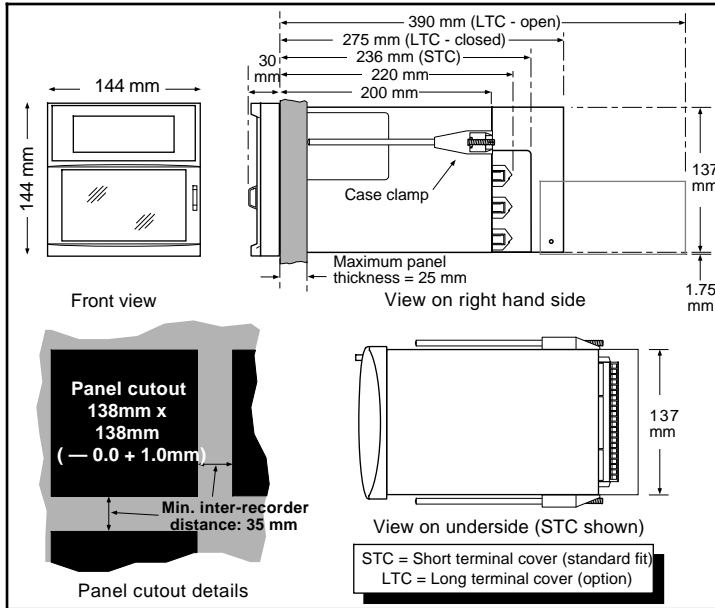

Supply voltage and input board termination

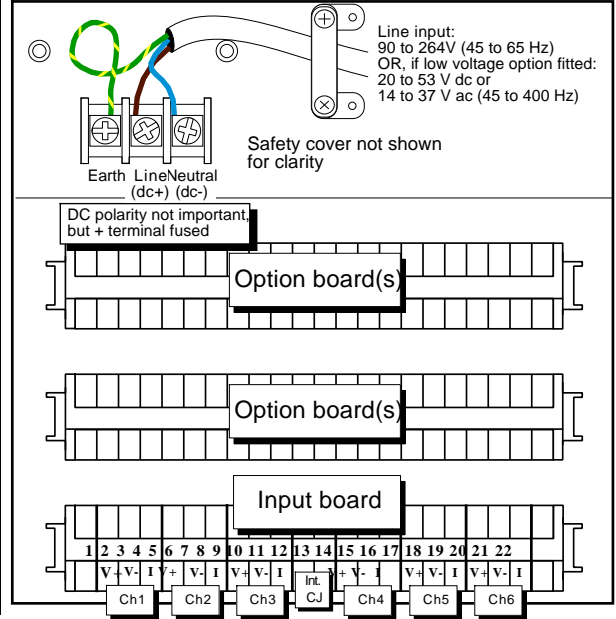

If ch1 = RTD, both legs of the internal CJ sensor are wired to terminal 11

Input board signal wiring

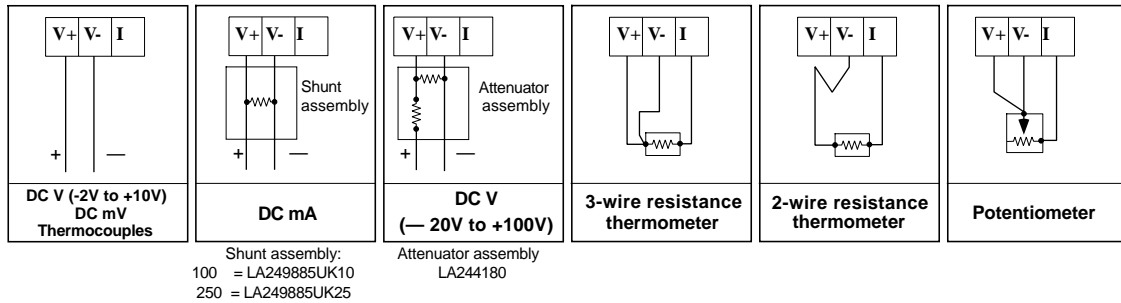

Option wiring

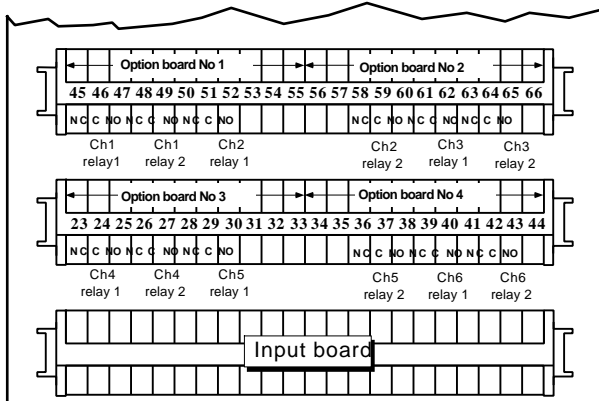

3 Changeover relays option

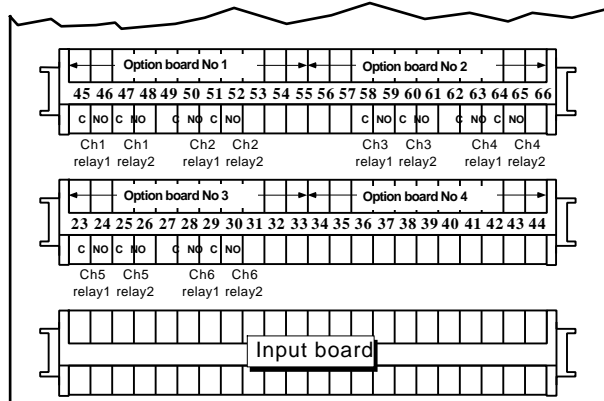

4 normally open relays option

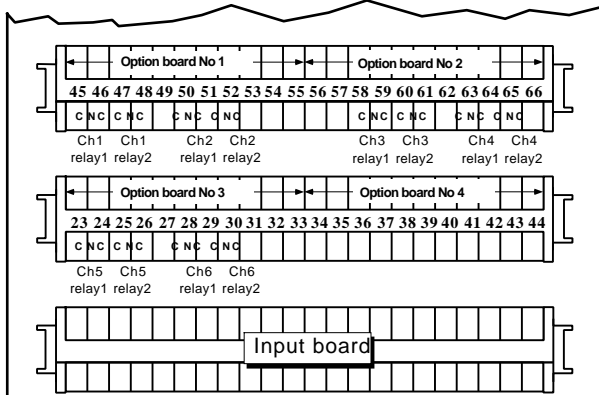

4 normally closed relays option

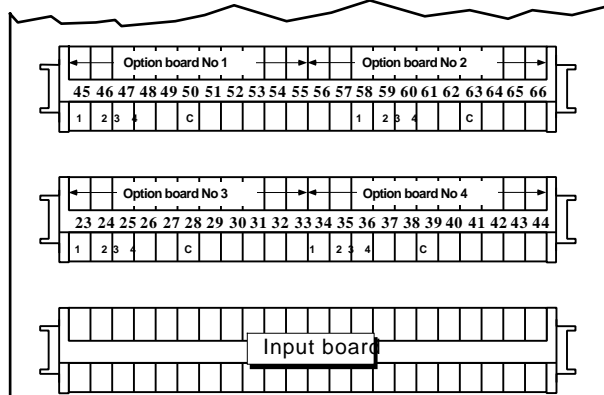

Event input board (alternative locations)