

IO Expander Type 2000IO

Installing and Operating Instructions

Thank you for choosing the IO Expander.

The IO Expander is used in conjunction with the 2604 and 2704 controllers to allow the number of digital IO points to be increased. There are two versions:-





1. 10 Inputs and 10 Outputs
2. 20 Inputs and 20 Outputs

Each input is fully isolated and voltage or current driven. Each output is also fully isolated consisting of four changeover contacts and six normally open contacts in the 10 IO version and four changeover and sixteen normally open contacts in the 20 IO version.

SUITABILITY

The IO Expander is suitable for use with 2604 and 2704 controllers fitted with Cross Board versions 4.5 or greater. These boards were fitted from August 2000.

To check the CBC version on the controller:

1. Enter configuration level.
2. Use  and  or  buttons to select the INSTRUMENT Info page.
3. Use  button to scroll to 'CBC Version'. The value read in the lower right of the display should be 45 or greater.
4. Exit configuration level.

The principle of this procedure is described in the 2604 and 2704 Engineering manuals, part numbers HA026761 and HA026933 respectively.

DATA TRANSFER

Data transfer is performed serially via a two wire interface as shown in Figure 1-1.

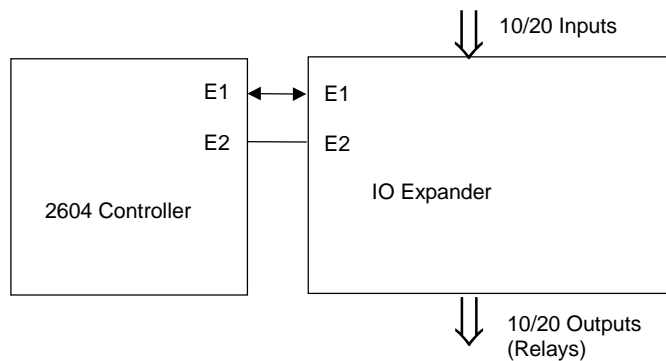

Figure 1-1: IO Expander Data Transfer

DIMENSIONS

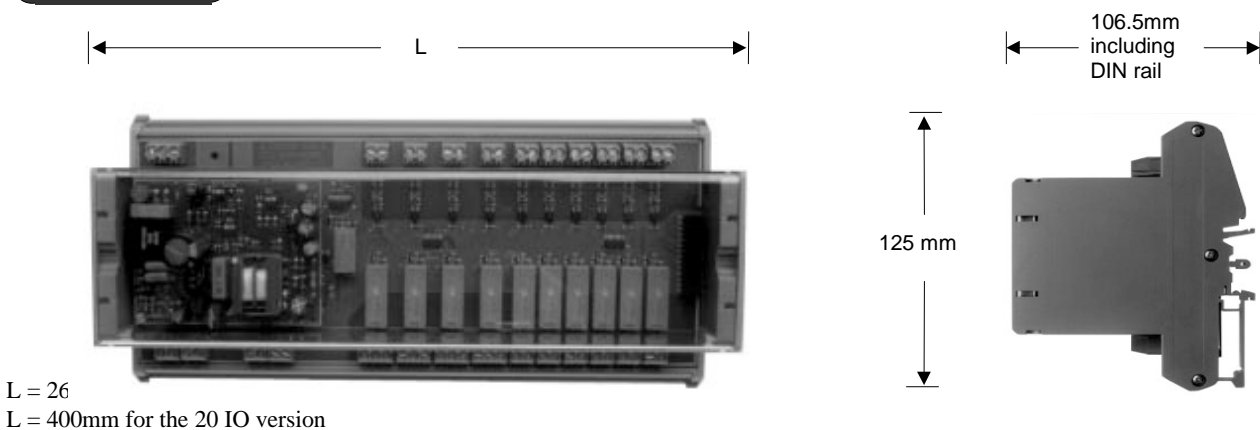

Figure 1-2: Dimensions

MOUNTING

The IO Expander is intended to be mounted within an enclosure, or an environment suitable for IP20 equipment.

It can be mounted on either symmetrical or asymmetrical DIN rail, to EN50022-35 x 7.5 or 35 x 15.

To mount the unit hold it parallel with the DIN rail and gently clip it into place.

It is not necessary to remove the protective cover when mounting or wiring the IO Expander.

The 10 Input/10 Output Expander

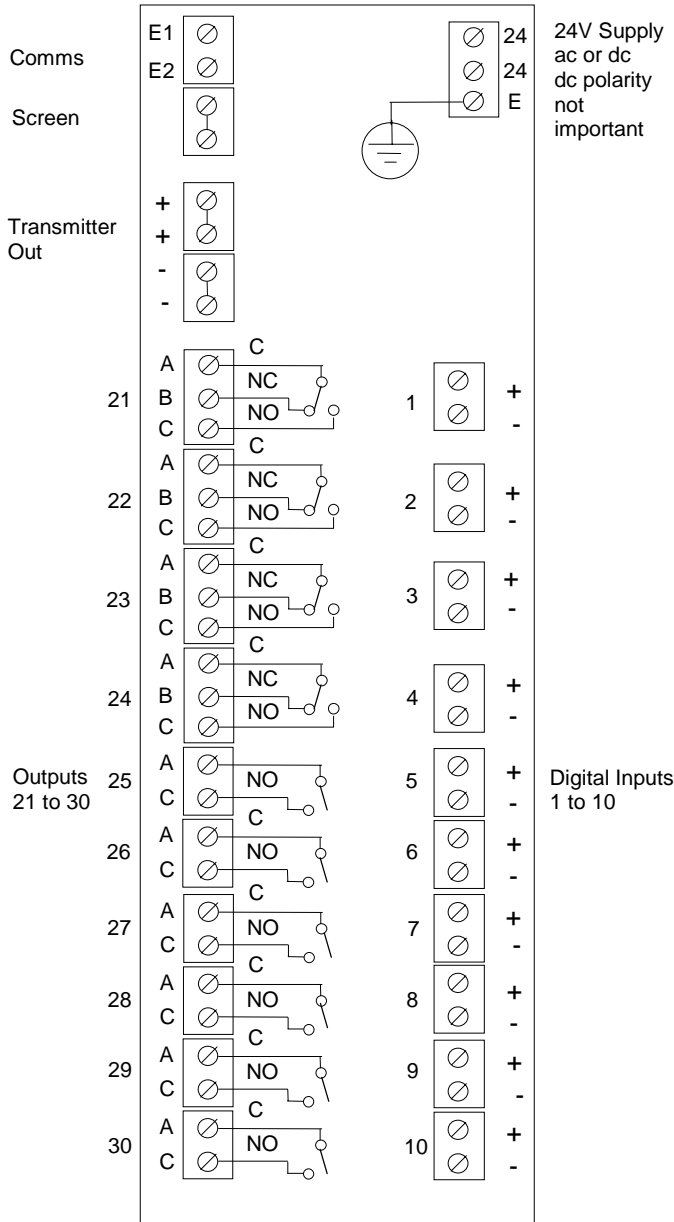

Figure 1-3: 10 Input/10 Output IO Expander Terminals

Electrical Connections

All electrical connections are made to the screw terminals which should be tightened to a torque of between 0.5 and 0.7Nm (4.3 - 4.9 lbin).

Communications Terminals

E1 and E2 are the terminal numbers on both Controller and IO Expander. It is recommended that a cable length of 10 metres is not exceeded, however, no shielding or twisted pair cable is required.

When this unit is connected to the controller it is necessary to set up parameters in the controller to determine its operation. This is described in the relevant instrument handbook.

Transmitter Power Supply

The IO Expander has a 24Vdc transmitter power supply capable of driving all 20 inputs. The terminals for this supply are shown in Figure 1-2.

The 20 Input/20 Output Expander

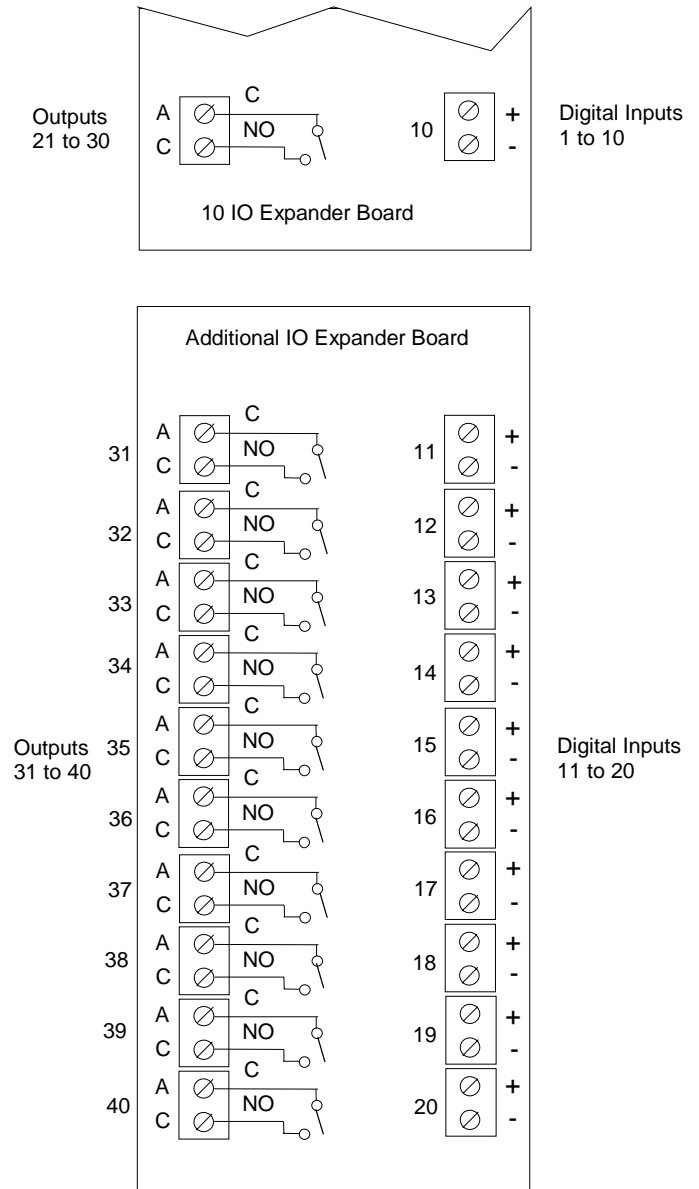

Figure 1-4: 20 Input/20 Output IO Expander Terminals

Logic Inputs

All inputs are fully isolated and can either be driven by a voltage or a current signal. Each logic input has a LED to indicate its active state. See 'Technical Specification' for switching levels.

Relay Outputs

All outputs are fully isolated and each has a LED to indicate its active state. See 'Technical Specification for contact ratings.

LED Indicators

The following LED indicators are provided:

1. Power to the unit is shown by an LED indicator
2. Communications to the unit is shown by the power on indicator which flashes when communications is active
3. Each logic input has a LED to indicate its active state.
4. Each output has a LED indication to show the state of the output.

ORDERING CODE

Product	Supply	IO Set 1	IO Set2
2000IO	VL	10 LR	

Supply	
VL	Low Voltage

IO Set 1	
10LR	10 Logic in/ 10 Relay out

IO Set 2	
XXXX	None fitted
10LR	10 Logic in/ 10 Relay out

TECHNICAL SPECIFICATION

General

Supply	20.4 to 28.8Vac (48 to 62Hz) or 20.4 to 26.4Vdc
Sealing	IP20 rated
Weight	10 IO: 0.66Kg, 20 IO: 1.0Kg
Temperature and RH	Operating 0 to 55°C, 5-95% RH non condensing
EMC standards	EN50081-1 & EN50082-2 generic standards - suitable for domestic, commercial and light industrial as well as heavy industrial environments
Safety standards	Meets EN61010 installation category II, pollution degree 2
Atmospheres	Not suitable for use above 2000m or in explosive or corrosive atmospheres

Relay outputs

10 IO version	4 changeover contacts 6 normally open contacts
20 IO version	4 changeover contacts 16 normally open contacts
Rating	Min 1Vdc, 1mA, 264Vac, 2A resistive

Logic Inputs

Number of inputs	20 max.
Current sinking	Active 9Vdc to 30Vdc @ 15mA Inactive 0 to 2Vdc @ < 0.5mA

Transmitter supply

20 to 26.4Vdc @ 200mA

Communications

Serial comms via a proprietary two wire interface: Max. cable length 10 metres

SAFETY AND EMC INFORMATION

Safety

This unit complies with the European Low Voltage Directive 73/23/EEC, amended by 93/68/EEC, by the application of the safety standard EN 61010.

Electromagnetic compatibility

This unit conforms with the essential protection requirements of the EMC Directive 89/336/EEC, amended by 93/68/EEC, by the application of a Technical Construction File. This unit satisfies the general requirements of the industrial environment defined in EN 50081-1 and EN 50082-2.

GENERAL

The information contained in these instructions is subject to change without notice. While every effort has been made to ensure the accuracy of the information, Eurotherm Controls shall not be held liable for errors contained herein.

Unpacking and storage

The packaging should contain the IO Expander, and this instruction leaflet.

If the packaging or the IO Expander are damaged, do not install it but contact the company where you purchased the product.

SERVICE AND REPAIR

This unit has no user serviceable parts. Contact your nearest Eurotherm Controls agent for repair.

Caution: Charged capacitors

Before removing the unit from its sleeve, switch off the supply and wait two minutes to allow capacitors to discharge. Failure to observe this precaution may damage unit or cause some discomfort to the user.

Electrostatic discharge precautions

If the unit is removed from its cover, it is vulnerable to damage by electrostatic discharge from someone handling the unit. To avoid this, before handling the PCB discharge yourself to ground.

Cleaning

Do not use water or water based products to clean labels or they will become illegible. Isopropyl alcohol may be used to clean labels. A mild soap solution may be used to clean other exterior surfaces of the product.

Safety Symbols

The following safety symbols are used on the controller:

 Caution, (refer to the accompanying documents)  Functional earth (ground) terminal

Personnel

Installation must be carried out by qualified personnel.

Enclosure of live parts

The unit must be installed in an enclosure to prevent hands or metal tools touching parts that may be electrically live.

Wiring

Wire the unit in accordance with the wiring data given in these instructions. Take particular care not to connect AC supplies to the low voltage logic inputs. Only use copper conductors for connections. Ensure that the installation complies with local wiring regulations.

Power Isolation

The installation must include a power isolating switch or circuit breaker that disconnects all current carrying conductors. The device should be mounted in close proximity to the unit, within easy reach of the operator and marked as the disconnecting device for the unit.

Voltage Rating

The maximum continuous voltage applied between any connection and ground must not exceed 264Vac.

For the above reason the unit should not be wired to a three phase supply with an unearthed star connection. Under fault conditions

such a supply could rise above 264Vac with respect to ground and the product would not be safe.

Conductive pollution

Electrically conductive pollution must be excluded from the cabinet in which the unit is mounted. For example, carbon dust is a form of electrically conductive pollution. Where condensation is likely, for example at low temperatures, include a thermostatically controlled heater in the cabinet.

Installation requirements for EMC

- For general guidance refer to Eurotherm Controls EMC Installation Guide, HA025464.
- It may be necessary to fit a filter across relay outputs to suppress conducted emissions. The filter requirements will depend on the type of load. For typical applications we recommend Schaffner FN321 or FN612.

Routing of wires

To minimise the pick-up of electrical noise, the sensor input wiring should be routed away from high-current power cables. Where it is impractical to do this, use shielded cables with the shield grounded at both ends.

INTERNATIONAL SALES AND SERVICE

EUROTHERM CONTROLS LTD

Faraday Close, Durrington,
Worthing, West Sussex
BN13 3PL
Telephone:
Sales: (01903) 695888
Technical: (01903) 695777
Fax: (01903) 695666
<http://www.eurotherm.co.uk>

Countries not listed -
enquiries/orders to:
Eurotherm Controls Limited,
Export Dept., Faraday Close,
Durrington,
Worthing, West Sussex,
BN13 3PL
Telephone (01903) 268500
Fax (01903) 265982
Telex 87114 EUROWG G

AUSTRALIA
Eurotherm Pty. Ltd.
Telephone Sydney
(+61 2) 96348444
Fax (+61 2) 96348555

AUSTRIA
Eurotherm GmbH
Telephone Vienna
(+43 1) 798 7601
Fax (+43 1) 798 7605

BELGIUM
Eurotherm B.V.
Telephone Antwerp
(+32 3) 322 3870
Fax (+32 3) 321 7363

DENMARK
Eurotherm A/S
Telephone Copenhagen
(+45 38) 871622
Fax (+45 38) 872124

FRANCE
Eurotherm Automation SA
Telephone Lyon
(+33 478) 664500
Fax (+33 478) 352490

GERMANY
Eurotherm Regler GmbH
Telephone Limburg
(+49 6431) 2980
Fax (+49 6431) 298119

HONG KONG
Eurotherm Limited
Telephone Hong Kong
(+852) 28733826
Fax (+852) 2870 0148
Telex 0802 69257 EIFEL HX

INDIA
Eurotherm India Limited
Telephone Chennai
(+9144) 4961129
Fax (+9144) 4961831

IRELAND
Eurotherm Ireland Limited
Telephone Naas
(+353 45) 879937
Fax (+353 45) 875123

ITALY
Eurotherm SpA
Telephone Como
(+39 31) 975111
Fax (+39 31) 977512
Telex 380893 EUROTH I

JAPAN
Densei-Lambda K.K.
Eurotherm Division
Telephone Tokyo
(+81 3) 5714 0620
Fax (+81 3) 5714 0621

KOREA
Eurotherm Korea Limited
Telephone Seoul
(+82 2) 4888507
Fax (+82 2) 4888508
Telex EIKOR K23105

NETHERLANDS
Eurotherm B.V.
Telephone Alphen a/d Ryn
(+31 172) 411752
Fax (+31 172) 417260

NEW ZEALAND
Eurotherm Limited
Telephone Auckland
(+64 9) 2635900
Fax: (+64 9) 2635901

NORWAY
Eurotherm A/S
Telephone Oslo (+47 67)
592170
Fax (+47 67) 118301

SPAIN
Eurotherm España SA
Telephone (+34 91) 6616001
Fax (+34 91) 6619093

SWEDEN
Eurotherm AB
Telephone Malmo
(+46 40) 384500
Fax (+46 40) 384545

SWITZERLAND
Eurotherm Produkte (Schweiz)
AG
Telephone Zurich
(+41 55) 4154400
Fax (+41 55) 4154415

UNITED KINGDOM
Eurotherm Controls Limited
Telephone Worthing
(+44 1903) 268500
Fax (+44 1903) 265982

U.S.A
Eurotherm Controls Inc.
Telephone Leesburg
(+1 703) 443 0000
Fax (+1 703) 669 1300
Web www.eurotherm.com